

URS

*Tramline Control*

Author  
Type of document  
Status of document  
Language  
Storage location  
Version / date

helwegk  
URS  
Draft  
English  
TramlineControl\_BasicRequirements\_v1.12.docx  
24.01.2017

**CCISOBUS**

Copyright

This document is protected by copyright. All rights, even the rights of translation, reprint, duplication or parts of this document, are reserved.

## Inhalt

<b>1</b>	<b>GENERAL.....</b>	<b>5</b>
1.1	Tracking.....	5
1.2	History.....	5
1.1	General Overview.....	8
1.2	Terms and definitions.....	8
1.2.1	Bout.....	8
1.2.2	Tramline.....	8
1.2.3	Symmetric Tramlines.....	8
1.2.4	Asymmetric Tramlines.....	8
1.2.5	Tramline Rhythm.....	8
1.2.6	Bout Track Number.....	8
1.2.7	Guidance Track Number.....	8
1.3	Tramline Control Levels.....	9
1.3.1	Level 1 – Guidance System as broadcast system.....	9
1.3.2	Level 2 – Guidance System / Task Controller, Implement calculates tramlines.....	10
1.3.3	Level 3 – Task Controller calculates tramlines.....	11
<b>2</b>	<b>TRAMLINE CONTROL SYSTEM REQUIREMENTS.....</b>	<b>12</b>
2.1	Task Controller as Tramline Controller.....	12
2.2	Guidance Controller broadcasting Guidance Line information.....	12
2.3	Required parameters (DDIs).....	12
2.3.1	DDI 515 Tramline Control State.....	13
2.3.2	DDI 505 Tramline Control Level.....	13
2.3.3	DDI 506 Setpoint Tramline Control Level.....	13
2.3.4	DDI 70 Maximum Working Width.....	13
2.3.5	DDI Crop protection/fertilization Working Width.....	14
2.3.6	DDI Tramline Tire Width.....	14
2.3.7	DDI Tramline Wheel Distance.....	14
2.3.8	DDI Tramline Irrigation Working Width.....	15
2.3.9	DDI Tramline Irrigation Tire Width.....	15
2.3.10	DDI Tramline Irrigation Wheel Distance.....	16
2.3.11	DDI Working Direction.....	16
2.3.12	DDI 508 Unique A-B Guidance Reference Line ID.....	16
2.3.13	DDI 509 Actual Track Number.....	17
2.3.14	DDI 510 Track Number to the right.....	17
2.3.15	DDI 511 Track Number to the left.....	17
2.3.16	DDI 512 Guidance Line Swath Width.....	18
2.3.17	DDI 513 Guidance Line Deviation.....	18
2.3.18	DDI 514 GNSS Quality.....	19
2.3.19	DDI 516 Tramline Overdosing Rate.....	19
2.3.20	DDI 518 Actual Tramline Condensed Work State 1-16.....	19
2.3.21	DDI 517 Setpoint Tramline Condensed Work State 1-16.....	19
2.3.22	DDI 507 Tramline Sequence Number.....	20
2.3.23	DDIs Distances between Guidance Track Number 0 <sub>R</sub> and 1, and Track 0 <sub>R</sub> and 0 <sub>L</sub> .....	20
2.3.24	DDI Bout Track Number Shift.....	21

**2.4 Steps to set up a basic Tramline Control System.....22**

2.4.1 Set up Tramline Control Level .....23

2.4.2 Set up Working Widths .....23

2.4.3 Set up Track Number 0 (A-B line) position .....23

2.4.4 Set up Working Width for the first Bout .....23

**3 EXAMPLES FOR TRAMLINE CONTROL ..... 23**

3.1 Asymmetric Tramlines, starting with 100% Working Width .....23

3.2 Symmetric Tramlines, starting with 50% Working Width (left side working) .....24

3.3 Symmetric Tramlines, starting with 50% Working Width (middle working).....26

3.4 Asymmetric Tramlines, first finish surrounding headland, then the main field .....27

**4 ANNEX ..... 29**

4.1 Requirements for Tramline Control Level 3.....29

## 1 General

### 1.1 Tracking

Modifications to the previous version are marked with a **green** background.

Open issues are marked with a **light blue** background.

Missing information, images etc. are marked with a **yellow** background.

### 1.2 History

Version	Comment	Date	Name
<b>1.0</b>	Initial version	14.07.2015	Karsten Helweg
<b>1.1</b>	Corrections after review of the group	15.07.2015	Karsten Helweg
<b>1.2</b>	Changes from Martijn van der Bijl <ul style="list-style-type: none"> <li>- Added 3 Levels of Tramline Systems</li> <li>- Added example for first seeding a surrounding headland before main field</li> </ul> Changes from Karsten Helweg <ul style="list-style-type: none"> <li>- Added sequence diagrams to examples</li> </ul> Changes from Jörg Boese <ul style="list-style-type: none"> <li>- Added definition for Field Border Position</li> </ul> Changes from Hans van Zadelhoff <ul style="list-style-type: none"> <li>- Added comments to definition of Field Border Position</li> </ul>	22.07.2015	Karsten Helweg
<b>1.3</b>	Corrections after telco from 22.07.2015 <ul style="list-style-type: none"> <li>- Use own PGN if Tramline Controller is not the Task Controller</li> <li>- Added missing parameter Guidance Reference Line ID</li> <li>- Added parameter Tramline Control Sequence</li> <li>- Corrected sequence diagrams</li> </ul>	24.07.2015	Karsten Helweg
<b>1.4</b>	Changes from Hans van Zadelhoff <ul style="list-style-type: none"> <li>- Field Border Position / Working Direction</li> <li>- Track Number Offset</li> </ul> Changes from Martijn van der Bijl <ul style="list-style-type: none"> <li>- Added some more detailed descriptions</li> </ul>	12.08.2015	Karsten Helweg
<b>1.5</b>	Corrections after telco from 12.08.2015 <ul style="list-style-type: none"> <li>- Corrected some pictures and text sections</li> <li>- Removed obsolete text sections</li> </ul> Changes from Martijn van der Bijl <ul style="list-style-type: none"> <li>- Added section for Tramline Control Level 3</li> </ul>	19.08.2015	Karsten Helweg

<b>1.6</b>	<p>Changes from Martijn van der Bijl</p> <ul style="list-style-type: none"> <li>- Added DDI definitions for <ul style="list-style-type: none"> <li>o Maximum Tramline Configuration Level</li> <li>o Setpoint Tramline Configuration Level</li> <li>o Tramlining Sprayer Tire Width</li> <li>o Tramlining Sprayer Wheel Distance</li> <li>o Tramlining Sprayer Single or Double Tramline Track</li> <li>o Irrigation Working Width</li> <li>o Tramlining Irrigation Tire Width</li> <li>o Tramlining Irrigation Wheel Distance</li> <li>o Tramlining Irrigation or Double Tramline Track</li> <li>o Guidance Line Swath Width</li> <li>o Guidance Line Deviation</li> <li>o GNSS Quality</li> <li>o Tramlining Overdosing Rate</li> <li>o Actual Tramline Condensed Work State</li> <li>o Setpoint Tramline Condensed Work State</li> <li>o Tramline Guidance Track Offset</li> </ul> </li> <li>- Updated DDOP Examples</li> </ul>	27.08.2015	Karsten Helweg
<b>1.7</b>	<p>Added DDI Tramline Control State</p> <p>Changes from Hans van Zadelhoff</p> <ul style="list-style-type: none"> <li>- Updated description of DDIs <ul style="list-style-type: none"> <li>o GNSS Signal Quality</li> <li>o Tramlining Overdosing Rate</li> </ul> </li> </ul> <p>Changes from Gregor Gennep</p> <ul style="list-style-type: none"> <li>- Added overview of DDIs with sending direction and requirement level</li> </ul> <p>Changes from Matijn van der Bijl</p> <ul style="list-style-type: none"> <li>- Updated description and pictures for DDIs <ul style="list-style-type: none"> <li>o Setpoint Tramline Control Level</li> <li>o Tramline Single/Double Tramline Track</li> <li>o Tramlining Irrigation Working Width</li> <li>o Guidance Line Swath Width</li> <li>o Tramlining Overdosing Rate</li> </ul> </li> </ul>	16.09.2015	Karsten Helweg
<b>1.8</b>	<p>Corrections after telco from 16.09.2015</p> <ul style="list-style-type: none"> <li>- Added additional information for Tramline Control Levels</li> <li>- Removed DDI Tramlining Single or Double Tramline Track</li> <li>- Corrected picture and updated text for Guidance Line Deviation</li> <li>- Merged DDIs Tramline Guidance Track Offset and Bout Track Number Shift</li> <li>- Updated Sequence Diagrams for all Examples</li> </ul>	17.09.2015	Karsten Helweg
<b>1.9</b>	<p>Corrections after telco from 20.10.2015</p>	21.10.2015	Karsten Helweg
<b>1.10</b>	<p>Corrections after telco from 04.11.2015</p>	04.11.2015	Karsten Helweg

<b>1.11</b>	Corrections after DDMA meeting and feedback from 22.08.2016 - Change the Element Number to be used for Guidance Systems from 0xFFF to 0x000 (Implement has to take care)	30.08.2016	Karsten Helweg
<b>1.12</b>	Added official DDI numbers to document	24.01.2017	Karsten Helweg

**Table 1: History**

## 1.1 General Overview

This specification defines basic methods and requirements for a Tramline Control system consisting of an Implement (e.g. seeder), a Guidance System (Steering System) and a Tramline-Controller (e.g. Task Controller). The Guidance System and the Task Controller Software may be part of the same physical device. The Tramline-Controller may be also part of the Guidance System without having a Task Controller.

## 1.2 Terms and definitions

### 1.2.1 Bout

Bouts are the parallel Swathes with a Working Width going from one side to the other side of the field, as in mowing or seeding.

### 1.2.2 Tramline

Tramlines are the parallel lines in crops that allow the farmers to drive through the field for fertilizing or spraying without causing any damage on surrounding crops.

### 1.2.3 Symmetric Tramlines

Tramline tracks are located in one Bout.

### 1.2.4 Asymmetric Tramlines

Tramline tracks are divided over two consecutive Bouts.

### 1.2.5 Tramline Rhythm

Total number of seeding Bouts which are required to repeat the Tramline pattern. This is always a positive number  $> 0$ .

### 1.2.6 Bout Track Number

Repeating Track Number of a Bout, starting from 1 to the Tramline Rhythm Number.

### 1.2.7 Guidance Track Number

Number of the Track provided by the Guidance System. This Track Number is a unique number. Track number 0 is by definition always the A-B line itself. The Tracks on the right hand side in direction A to B will have ascending positive numbering, the Tracks on left hand side in direction A to B will have descending negative numbers.



### 1.3 Tramline Control Levels

With the introduction of GNSS in the agricultural industry, Implement devices may use the GNSS information as input for the tramlining track calculations instead of the signal from the track markers.

This document provides the specifications for 3 different levels in standardization for tramlining.

All related parameters are defined as DDIs in chapter 2.3.

#### 1.3.1 Level 1 – Guidance System as broadcast system

A Guidance System broadcasts its information required for tramlining on the network. There is no dedicated communication between the guidance system and the implement device.

The implement is calculating the tramline tracks.

Since the guidance system is only able to broadcast and the implement cannot send data to the guidance system (means no peer to peer communication between implement and guidance system), the farmer is responsible for shifting the Guidance Lines in case an asymmetric rhythm should be transferred to a symmetric rhythm. Examples for those different types of rhythms are shown in chapter 3.

The following table shows the list of DDIs to be used for a Level 1 Tramline System.

DDI (dec)	Description	Required or Optional	Direction
505	Tramline Control Level	required (for TC)	Implement->TC
506	Setpoint Tramline Control Level	required (for TC)	TC->Implement
507	Tramline Sequence Number	required	TC->Implement
508	Unique A-B Guidance Reference Line ID	required	GuidanceController Broadcast
509	Actual Track Number	required	GuidanceController Broadcast
510	Track Number to the right	required	GuidanceController Broadcast
511	Track Number to the left	required	GuidanceController Broadcast
512	Guidance Line Swath Width	required	GuidanceController Broadcast
513	Guidance Line Deviation	required	GuidanceController Broadcast
514	GNSS Quality	required	GuidanceController Broadcast

**Table 2: Level 1 DDIs**

### 1.3.2 Level 2 – Guidance System / Task Controller, Implement calculates tramlines

There is peer to peer communication between the Task Controller / Guidance System and the implement. The implement may send the tramline configuration information to the Task Controller, so the information can be stored and reused. Since the tramline configuration information is sent to the Task Controller / Guidance System, the Task Controller / Guidance System can create the  $0_R$  and  $0_L$  guidance lines automatically in case an asymmetric rhythm is transferred to a symmetric rhythm.

The seeder stays responsible for the calculation of the tramline tracks.

The following table shows the list of DDIs to be used for a Level 2 Tramline System. For the Task Controller it is required that all DDIs can be handled even if they are marked as optional in the table. For the Implement device these DDIs may be optional.

DDI (dec)	Description	Required or Optional	Direction
505	Tramline Control Level	required	Implement->TC
506	Setpoint Tramline Control Level	required	TC->Implement
515	Tramline Control State	required	Implement->TC TC->Implement
507	Tramline Sequence Number	required	TC->Implement
508	Unique A-B Guidance Reference Line ID	required	TC->Implement
509	Actual Track Number	required	TC->Implement
510	Track Number to the right	required	TC->Implement
511	Track Number to the left	required	TC->Implement
	Working Direction	optional required	Implement->TC TC->Implement
	Distance between Guidance Track $0_R$ and 1	required	Implement->TC
	Distance between Guidance Track $0_R$ and $0_L$	required	Implement->TC
513	Guidance Line Deviation	required	TC->Implement
514	GNSS Quality	required	TC->Implement
512	Guidance Line Swath Width	optional required	Implement->TC TC->Implement
	Bout Track Number Shift	optional	Implement->TC
70	Maximum Working Width	optional	Implement->TC
	Crop protection-fertilization Working Width	optional	Implement->TC
	Tramline Tire Width	optional	Implement->TC

	Tramline Wheel Distance	optional	Implement->TC
	Tramline Irrigation Working Width	optional	Implement->TC
	Tramline Irrigation Tire Width	optional	Implement->TC
	Tramline Irrigation Wheel Distance	optional	Implement->TC
516	Tramline Overdosing Rate	optional	Implement->TC
518	Actual Tramline Condensed Work State 1-16	required	Implement->TC

Table 3: Level 2 DDIs

### 1.3.3 Level 3 – Task Controller calculates tramlines

At this level the communication between the Task Controller and the Implement is standardized in such a way, that the Task Controller can inform the Implement device that it has to activate its mechanism to create a tramline track. The Task Controller is responsible for calculating the position of the tramline tracks in the field.

The following table shows the list of DDIs to be used for a Level 3 Tramline System.

DDI (dec)	Description	Required or Optional	Direction
505	Tramline Control Level	required	Implement->TC
506	Setpoint Tramline Control Level	required	TC->Implement
515	Tramline Control State	required	Implement->TC TC->Implement
70	Maximum Working Width	required	
516	Tramline Overdosing Rate	optional	Implement->TC
517	Setpoint Tramline Condensed Work State 1-16	required	TC->Implement
518	Actual Tramline Condensed Work State 1-16	required	Implement->TC

Table 4: Level 3 DDIs

## 2 Tramline Control system requirements

### 2.1 Task Controller as Tramline Controller

If there is a Task Controller which controls the Implement for tramlining, the Task Controller Process Data PGN (0x00CB00) defined in ISO 11783-10 shall be used. Following rules shall apply to send the values to the Implement:

- The TC shall use its own Source Address and the Implement's specific Destination Address
- The appropriate DDI and Element Number from the Implement's DDOP shall be used
- The TC may request the values with the RequestValueCommand
- The TC may use MeasurementCommands to request Values from the Implement

The Implement itself may use its appropriate DDI, Element Number and as Destination Address the Source Address of the Tramline Controller. The responses shall be sent with the same PGN as the received messages.

The Task Controller may store some information to a field. To do so, the related DDI may be defined as a task total inside the DDOP of the Implement (settable DPD with measurement type total). The Task Controller will store this value and sent this value back to the Implement upon a task resume. No matter if this value is a real total value, this is a way the Task Controller can save a Tramline Configuration and is able to send this configuration back to the Implement without any further adaptations. Since these DDIs are not real totals, a Task Controller could filter these values out for displaying purposes.

If Task Controller and Implement are both TC version 4 or later, the SetValueAndAcknowledgeCommand (0x0A) shall be used instead of the normal ValueCommand (0x03) to send values on the network. Previous versions may use the ValueCommand (0x03).

### 2.2 Guidance Controller broadcasting Guidance Line information

For other systems than Task Controller as Tramline Controller the PGN 0x00CB00 (as defined in ISO 11783-10) shall be used with the same content like the Task Controller PGN. The following rules shall apply to send the values to the Implement:

- The Tramline Controller shall use its own Source Address and Destination Address set to the Global Address (0xFF)
- The appropriate DDI shall be used with Element Number set to 0x000
- To send the values, the ValueCommand shall be used
- The communication is only a one-way-broadcast from the Tramline Controller to the Implement

**Note:** *The Implement has to take care about its own Element Number in this case, because the Tramline Controller sends always Element Number 0x000 whereas the real Element Number could be different inside the Implement's DDOP.*

### 2.3 Required parameters (DDIs)

To set up a basic Tramline System, at least the following parameters are required.

**Note:** *To preserve misleading numbering and having always full Working Widths between the Guidance Tracks, this specification requires, that the Guidance System can handle two Tracks with*

Number 0, the Tracks  $0_R$  and  $0_L$ . In this document the terms  $0_R$  and  $0_L$  are used, in the communication protocol only one value 0 is used.

### 2.3.1 DDI 515 Tramline Control State

The Tramline Control State has the same purpose and definition like the Section Control State DDI 160.

The value definitions are:

Byte 1 Bits 0-1 = 00 manual/off  
 Byte 1 Bits 0-1 = 01 automatic/on  
 Byte 1 Bits 0-1 = 10 error  
 Byte 1 Bits 0-1 = 11 undefined/not supported  
 Byte 1 Bits 2-7 reserved, set to 0.

The DDI shall support the On Change trigger so that the Task Controller is able to get informed when the value gets changed by the Working Set Master. The Task Controller shall activate this trigger when using the DDI.

### 2.3.2 DDI 505 Tramline Control Level

The Implement shall provide in its root DeviceElement which Tramline Control Levels are supported. The Tramline Control Levels are independent of each other. It is allowed to support for example only Level 3 Tramlining.

Bit 0 = 1 Support Tramline Level 1  
 Bit 1 = 1 Support Tramline Level 2  
 Bit 2 = 1 Support Tramline Level 3  
 Bit 3-7 = 0 Reserved

### 2.3.3 DDI 506 Setpoint Tramline Control Level

The Task Controller shall send this value to inform the Implement which Tramline Control Level shall be used to operate. In case there is no match between the supported Tramline Control Level on the Task Controller Server side and the Implement, the Task Controller shall inform the Implement by setting the Setpoint Tramline Control Level to 0.

0 No common Level  
 1 Tramline Control Level 1  
 2 Tramline Control Level 2  
 3 Tramline Control Level 3  
 4-255 Reserved for future Assignment

### 2.3.4 DDI 70 Maximum Working Width

This is the Working Width of the Seeder. This is also the distance between the single Guidance/Bout Tracks. This value is provided by the Seeder Implement as its own Maximum Working Width (already existing DDI 70). This value depends on the current setup of the Implement.

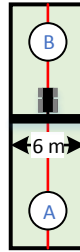

Figure 1: Seeder Working Width

### 2.3.5 DDI Crop protection/fertilization Working Width

Working Width of the Crop protection/fertilization vehicle. This is also the distance between the single Tramline Tracks. This value is a manual user input and is provided by the Implement to the Guidance System.

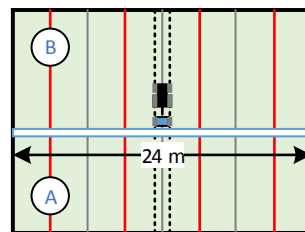

Figure 2: Crop protection/fertilization Working Width

### 2.3.6 DDI Tramline Tire Width

This is the Width of the largest tire which should fit on the Tramline Track. The distance between the rows besides the Tramline Track shall be wider than the Tire Width to avoid crop damage.

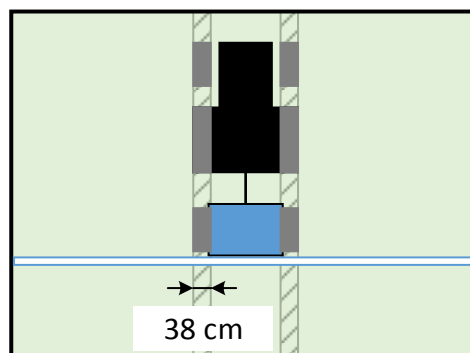

Figure 3: Tramline Tire Width

### 2.3.7 DDI Tramline Wheel Distance

This is the distance between the centres of the Wheels of the Sprayer/Tractor.

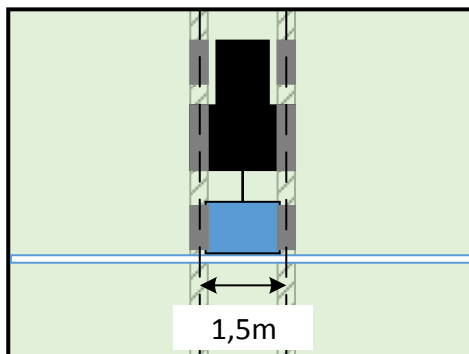

Figure 4: Tramlining Wheel Distance

### 2.3.8 DDI Tramline Irrigation Working Width

Besides a Tramlining rhythm for a Sprayer, a second Tramlining rhythm with a different pattern for an irrigation system may exist.

The Working Width of the Irrigation system is also the Distance between the single Tramline Tracks for the Irrigation system. This value is a manual user input and is provided by the Implement to the Tramline Controller.

The following picture shows an example with a 6m Seeddrill Width, 24m Sprayer Width and a 66m Irrigation Width.

Sprayer Bout Track Nr.	1	2	3	4	1	2	3	4	1	2	3	4	1
Irrigation Bout Track Nr.	1	2	3	4	5	6	7	8	9	10	11	1	2
	0	1	2	3	4	5	6	7	8	9	10	11	12

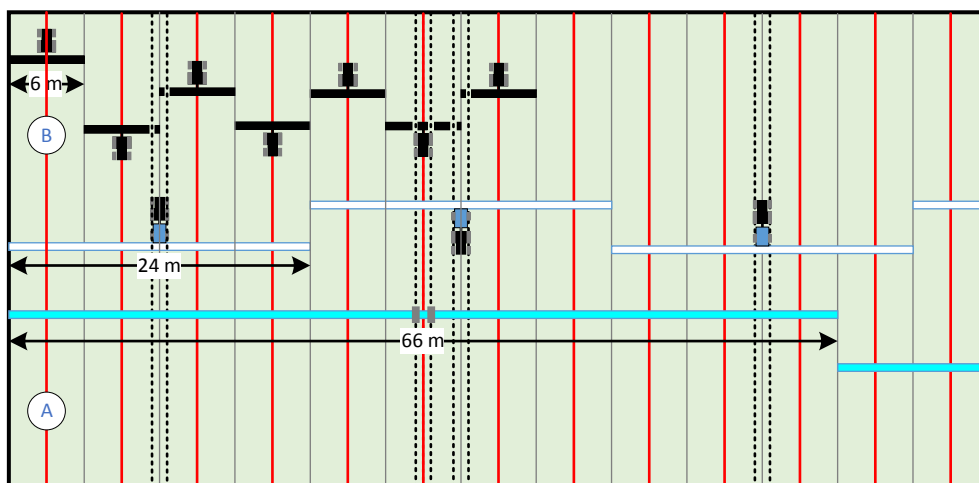

Figure 5: Different Tramline Widths

### 2.3.9 DDI Tramline Irrigation Tire Width

This is the Width of the largest Tire which should fit on the Tramline Track. The distance between the rows besides the Tramline Track shall be wider than the Irrigation Tire Width to avoid crop damage.

### 2.3.10DDI Tramline Irrigation Wheel Distance

This is the Distance between the centre of the Wheels of the Irrigation system.

### 2.3.11DDI Working Direction

The Working Direction defines the intended Working Direction in the field and also defines the numbering of the Bouts. If the Working Direction is 1 (working from left to right, compared to AB-reference line) the numbering of the Bouts is also from left to right in ascending order. If the Working Direction is 2 (working from right to left, compared to AB-reference line) the numbering of the Bouts is from right to left in ascending order.

For Working Direction = 1 the numbering of Bouts and Guidance Tracks are increasing from left to right.

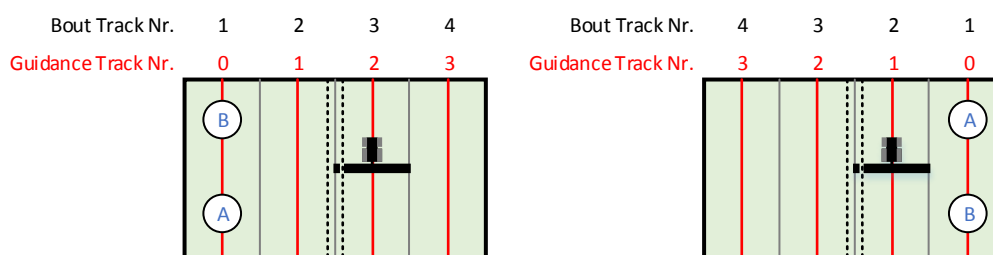

Figure 6: Working Direction = 1 from left to right in A-B direction

For Working Direction = 2 the numbering of Bout Tracks are increasing and the Guidance Tracks are decreasing from right to left.

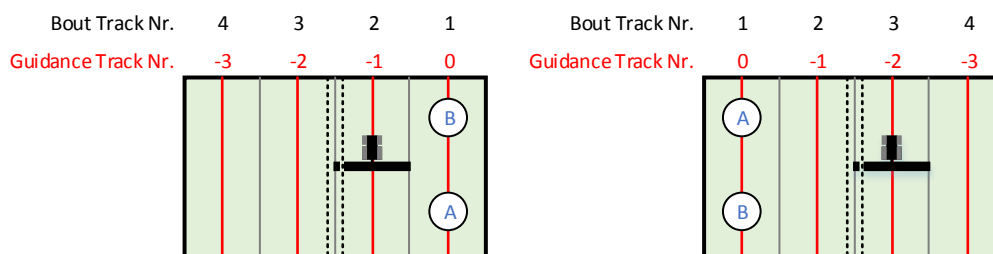

Figure 7: Working Direction = 2 from right to left in A-B direction

Working Direction = 0 means that the direction is unknown. In this case it is up to the implement how to deal with it. The user may be forced to enter a proper value.

This is a parameter for the internal Implement setup. This information may be stored to the field information. The Guidance System does not necessarily need this information. A Task Controller may send this value back to the Implement upon a task resume.

### 2.3.12DDI 508 Unique A-B Guidance Reference Line ID

A field could have more than one Guidance Reference Line. For example the field could have a Guidance Reference Line for the headland and also another Guidance Reference Line for the main field. To distinguish between the several Guidance Reference Lines a Guidance Reference Line ID is used. This unique ID identifies which Guidance Reference Line is the base for the Tramline calculation.



2.3.13DDI 509 Actual Track Number

The Actual Track Number is the unique Number of the Guidance Track the Implement is currently located on. This number is provided by the Guidance System.

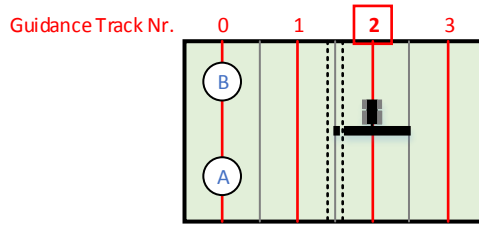

Figure 8: Actual Track Number

2.3.14DDI 510 Track Number to the right

This is the Guidance Track Number to right hand side in direction of Implement orientation. If the Track Number to the right is higher than the Actual Track Number, then the Implement is in the same direction as the A-B reference line. The Implement orientation is independent of the driving direction of the Implement. This value is provided by the Guidance System.

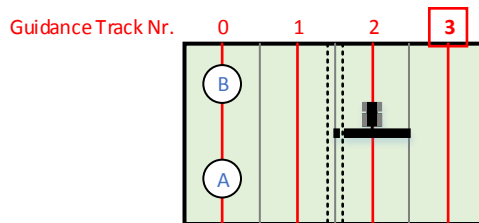

Figure 9: Track Number to the right

2.3.15DDI 511 Track Number to the left

This is the Guidance Track Number to left hand side in Implement orientation. This value may be used in addition to the Track Number to the right for differentiating between the two Guidance Track 0 Numbers (0<sub>R</sub> and 0<sub>L</sub>). This value is needed, because there are two cases where the Actual Track Number and the Track Number to the right are both 0. This value is provided by the Guidance System.

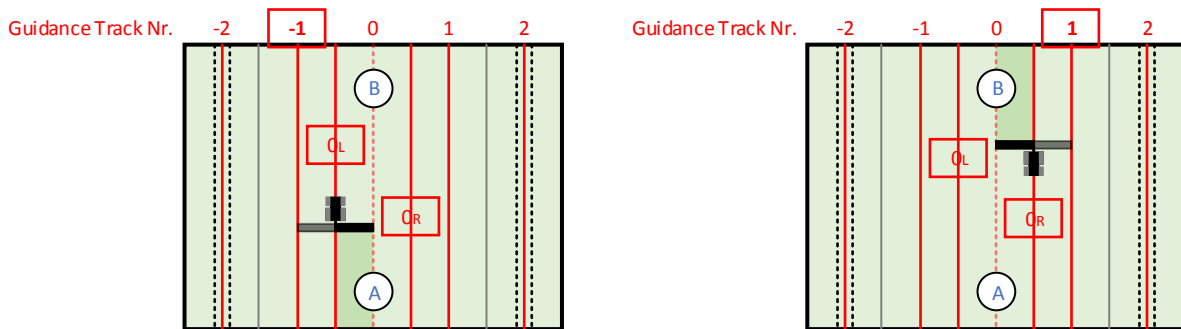

Figure 10: Track Number to the left

The following table contains some possible combinations for the Track Numbers.

Use case implement is on Track and orientation:	0 <sub>LAB</sub>	0 <sub>LBA</sub>	0 <sub>AB</sub>	0 <sub>BA</sub>	0 <sub>RAB</sub>	0 <sub>RBA</sub>
Actual Track Number	0	0	0	0	0	0
Track Number to the right	0	-1	1	-1	1	0
Track Number to the left	-1	0	-1	1	0	1

**2.3.16DDI 512 Guidance Line Swath Width**

The Swath Width is the Distance between two adjacent Guidance Lines in a Guidance Pattern. The User may prefer to choose a distance between two adjacent Guidance Lines which is a little smaller or bigger than the Seeder Working Width. The Implement may use this information to apply correction on its Tramline calculation.

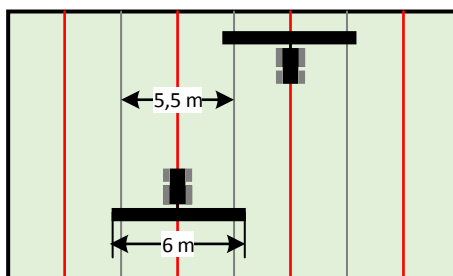
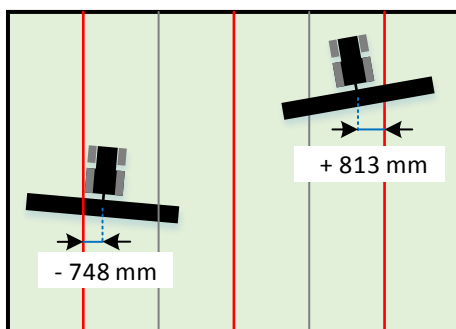

**Figure 11: Guidance Swath Width is smaller than Seeder Working Width**

**2.3.17DDI 513 Guidance Line Deviation**

This DDI shall be sent from the Guidance System or Task Controller. Looking from the Implement to the Actual Track Number (unique Guidance Track Number), it specifies the Deviation in mm from this Guidance Line and the Device Reference Point which is guided along the Guidance Line. The Guidance Line Deviation is positive when the Guidance Line is located on the right hand side of the Device Reference Point. The Guidance Line Deviation is negative when the Guidance Line is located on the left hand side of Device Reference Point.

The Implement may use this information to inform the operator that a proper Tramline calculation isn't possible from a certain value.



**Figure 12: Guidance Line Deviation**

### 2.3.18DDI 514 GNSS Quality

This DDI shall be sent from the Guidance System or Task Controller to the implement. It specifies the quality of the GNSS which was used by the Guidance System. The GNSS receiver may not have a direct communication to the Implement in case of NMEA 0183 receiver.

Definition references NMEA2000 MethodGNSS parameter as also mentioned in ISO11783-10.

### 2.3.19DDI 516 Tramline Overdosing Rate

This DDI specifies the Overdosing Rate for the rows adjacent to the Tramline Tracks. This value is specified in ppm. The value 1.000.000 (100%) is the normal rate. A value > 100% means that a overdosing is applied.

In case of a seeding distance, the implement should calculate the overdosing based on seeds per area and recalculate that value to an overdosing seeding rate.

Background: If the seeding distance is just multiplied with the overdosing rate, the seeding distance will increase which leads to less seed on the field!

Example: In the case the seeding distance is specified the overdosing rate will result in a shorter seed distance. A seeding distance of 20,00 cm with an overdosing rate of 110% will result in a seed distance of 18,18cm for the rows adjacent to the Tramline Tracks.

### 2.3.20DDI 518 Actual Tramline Condensed Work State 1-16

Combination of the Actual States of individual Tramline Valves number 1 to 16 into a single Actual Tramline State of their parent DeviceElement. The Actual Tramline Condensed Work State contains the child element Actual Tramline Work States, in the driving direction from left to right, where the leftmost child element Actual Tramline Work State are the 2 lowest significant bits of the Process Data Value. Each child device elements Actual Tramline Work State is represented by 2 bits and defined as: 00 = disabled/off, 01 = enabled/on, 10 = error indicator, 11 = undefined/not installed. In total 16 child device element Actual Tramline Work States can be contained in one Actual Tramline Condensed Work State of their parent DeviceElement. If less than 16 child device element Actual Tramline Work States are available, then the unused bits shall be set to value 11 (not installed).

### 2.3.21DDI 517 Setpoint Tramline Condensed Work State 1-16

The Setpoint Tramline Condensed Work State DDIs are the control command counterparts to the Actual Tramline Condensed Work States DDIs. The value is a combination of the Setpoint Tramline Valve Work States of individual Tramline Valves number 1 to 16 into a single Setpoint Tramline Work State of their parent DeviceElement. The Setpoint Tramline Condensed Work State contains the child element Setpoint Tramline Work States, in the driving direction from left to right, where the leftmost child element Setpoint Tramline Work State are the 2 lowest significant bits of the Process Data Value. Each child device elements Setpoint Work State is represented by 2 bits and defined as: 00 = disable/off, 01 = enable/on, 10 = error indicator, 11 = no change. In total 16 child device element Setpoint Tramline Work States can be contained in one Setpoint Tramline Condensed Work State of their parent DeviceElement. If less than 16 child device element Setpoint Tramline Work States are available, then the unused bits shall be set to value 11 (no change).

**2.3.22DDI 507 Tramline Sequence Number**

In order to ensure that the parameters "Unique A-B Guidance Reference Line ID", "Actual Track Number", "Track Number to the right" and "Track Number the left" are belonging together, the Tramline Sequence Number is needed. This parameter has to be sent from the Tramline Controller to indicate a new Tramline Sequence to the Implement. This number shall start with value 1 and increase on every new Tramline Sequence which is going to be sent.

These Parameters are only allowed to be sent in a group, except the Unique A-B Guidance Reference Line ID. If one of the parameters is missing, the Tramline Sequence would be invalid. It is up to the Implement how to behave in case of an invalid Tramline Sequence.

In case the Unique A-B Guidance Reference Line ID shall be part of the Tramline Sequence, this value shall be sent as first value after the Tramline Sequence Number and before other values.

It is recommended to send all values belonging to one Tramline Sequence within 500 ms.

**2.3.23DDIs Distances between Guidance Track Number 0<sub>R</sub> and 1, and Track 0<sub>R</sub> and 0<sub>L</sub>**

If the user wants to start with a different Working Width than 100%, the Track Number 0 has to be divided in two separate Tracks 0<sub>R</sub> and 0<sub>L</sub>. Therefore the Tracks 0<sub>R</sub> and 0<sub>L</sub> are deviated from the original Track 0. To calculate the correct positions of these Tracks, the distance  $d_{0R/1}$  between Track 0<sub>R</sub> and 1 and the distance  $d_{0R/0L}$  between 0<sub>R</sub> and 0<sub>L</sub> have to be defined.

This section defines two separate DDIs, one for  $d_{0R/1}$  and one for  $d_{0R/0L}$  although they are specified together in the same text and pictures.

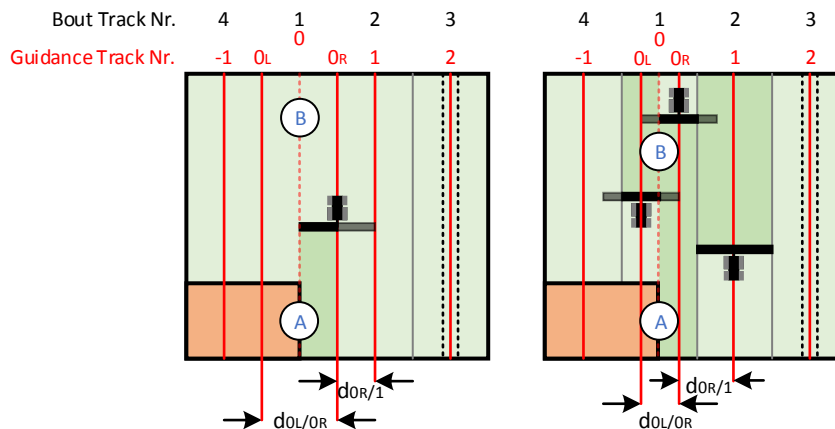

**Figure 13: Distance between Track 0<sub>R</sub> and 1, and Track 0<sub>R</sub> and 0<sub>L</sub>**

If a full Working Width shall be used for Track 0 in one working step, the distance  $d_{0R/1}$  between Track 0<sub>R</sub> and 1 is equal to the Working Width of the Seeder. In this case the distance  $d_{0R/0L}$  between 0<sub>R</sub> and 0<sub>L</sub> results in the value 0.

In all other cases the resulting Working Width of adding Track 0<sub>R</sub> and 0<sub>L</sub> shall cover 100% Working Width in order to fulfill equidistant distances between all Bout Tracks.

The distance between Track Number 0<sub>R</sub> and 1 depends on the Working Width of the Implement to the time of starting the work. Additionally, this value depends on the Seeder Implements properties, how a Working Width different to complete Width can be applied. One option may be working with

the complete right hand side or left hand side. The other option would be to work with the middle of the Implement and turn off the most right and most left side.

The Implement is responsible for the correct calculation of these distances in respect of the Implements properties. The distance  $d_{0R/1}$  between Track Number  $0_R$  and 1 and the distance  $d_{0R/0L}$  between Track Number  $0_R$  and  $0_L$  are provided by the Implement.

**2.3.24DDI Bout Track Number Shift**

Sometimes the calculated Tramline pattern needs to be shifted. For example if an obstacle (tree) is in the field.

The implement may have the possibility to give a Bout Track Number Shift in its calculation to shift the Tramline pattern. In that case the Tramline calculation is based on the following formula:

$$\text{Bout Track Number} = \text{Guidance Track Number} + 1 + \text{Bout Track Number Shift.}$$

The Task Controller shall store this information in conjunction with the Unique A-B Guidance Reference Line ID to the field. If a task gets started after being paused, the TC shall send this value to inform the implement that it needs to take this Bout Track Number Shift into account. Therefore this DDI should be settable.

The Guidance Track Numbers are not influenced by this DDI. A positive Bout Track Number Shift will shift the Tramline pattern in the direction of the lower Guidance Track Numbers. A negative Bout Track Number Shift will shift the Tramline pattern in the direction of the higher Guidance Track Numbers.

The following pictures show the influence of the Bout Track Number Shift.

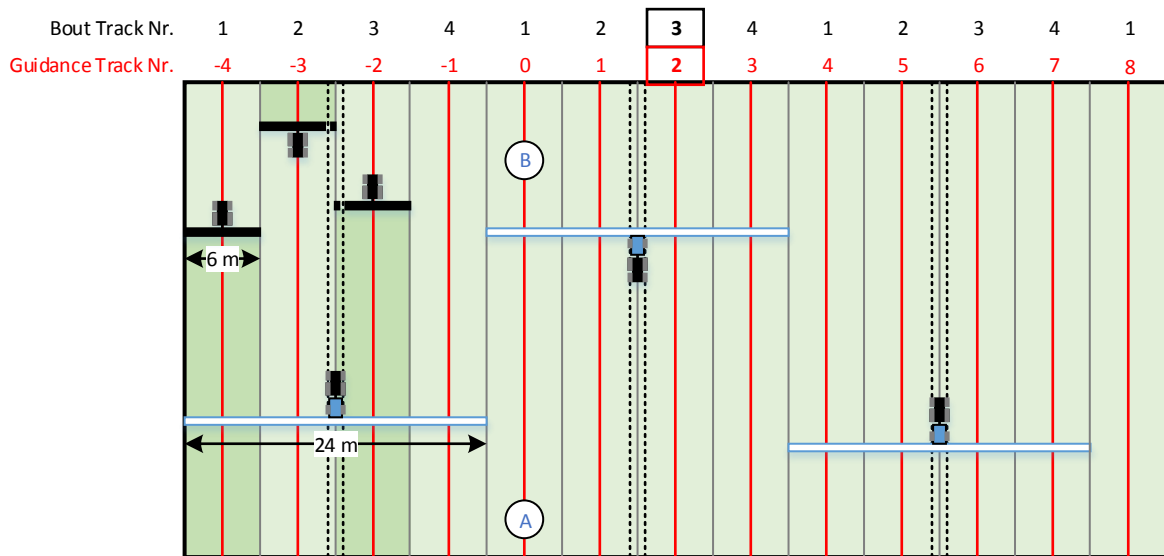

**Figure 14: Bout Track Number Shift = 0**

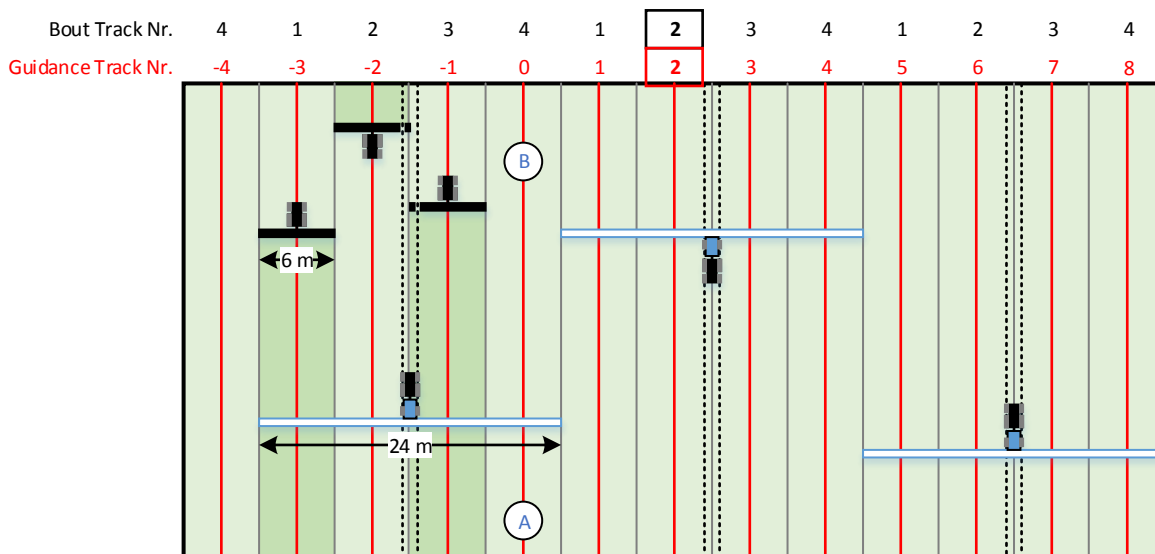

Figure 15: Bout Track Number Shift = -1

The Bout Track Number Shift may also be used for reusing an already existing A-B line. The main reason to reuse existing A-B lines is to avoid mistakes in using the wrong A-B line. The A-B Guidance Reference Line has per definition always the Guidance Track Number 0.

The following picture shows an example, where an existing A-B Guidance Reference Line is reused for a second part of the field. In this example, the existing A-B Guidance Reference Line on Guidance Track Number 0 is reused on Guidance Track Number 3. Therefore the Bout Track Number Shift is set to -3.

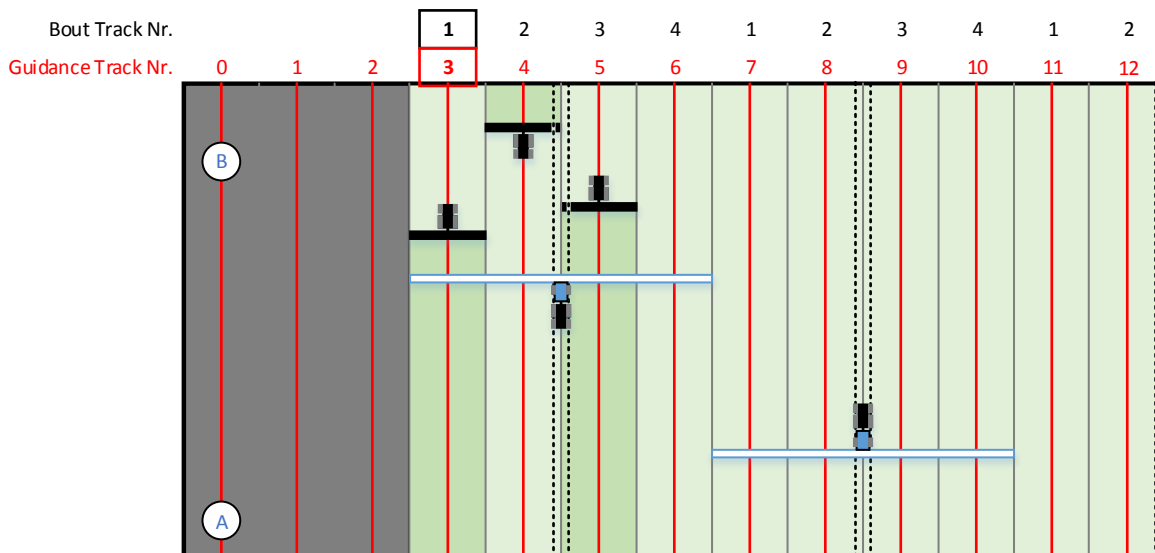

Figure 16: Bout Track Number Shift = -3

## 2.4 Steps to set up a basic Tramline Control System

To have the Tramline System ready to work, the following steps have to be carried out.

### 2.4.1 Set up Tramline Control Level

The Tramline Control Level has to be set up between Client and Server to define who has to calculate the Tramlines.

### 2.4.2 Set up Working Widths

The Working Width of the Seeder and the Working Width of the Sprayer/Fertilizer have to be defined to set the distances between the Guidance Tracks and Tramline Tracks.

### 2.4.3 Set up Track Number 0 (A-B line) position

Next to the Working Widths there has to be an A-B line. This A-B line is defined as Guidance Track Number 0. This line may be identified by the Unique A-B Guidance Reference Line ID. This is the starting point of the work for the rest of the field.

### 2.4.4 Set up Working Width for the first Bout

The Working Width the user wants to start with, together with the property of the Implement to fulfill the wanted working width, results in the distance  $d_{0R/1}$  between Track  $0_R$  and 1. This distance results therefore in the distance  $d_{0R/0L}$  between the Tracks  $0_R$  and  $0_L$ . See also section 2.3.23.

## 3 Examples for Tramline Control

In the following sections are detailed out some examples for different use cases for Tramline Control.

### 3.1 Asymmetric Tramlines, starting with 100% Working Width

The Seeder with 6m Working Width starts working with a full Working Width (100%, 6m) on Guidance Track Number 0 in direction of A-B line. The Working Direction is 1, which means the Field Border is on the left hand side of the Implement and the Guidance Track Numbering is increasing from left to right in A-B direction. The Sprayer has a Working Width of 24m. This results in a Tramline Rhythm of 4 Bout Tracks and an asymmetric Tramline on Bout Track Numbers 2 and 3. The Seeder will create a half Tramline on each Bout Number 2 and 3.

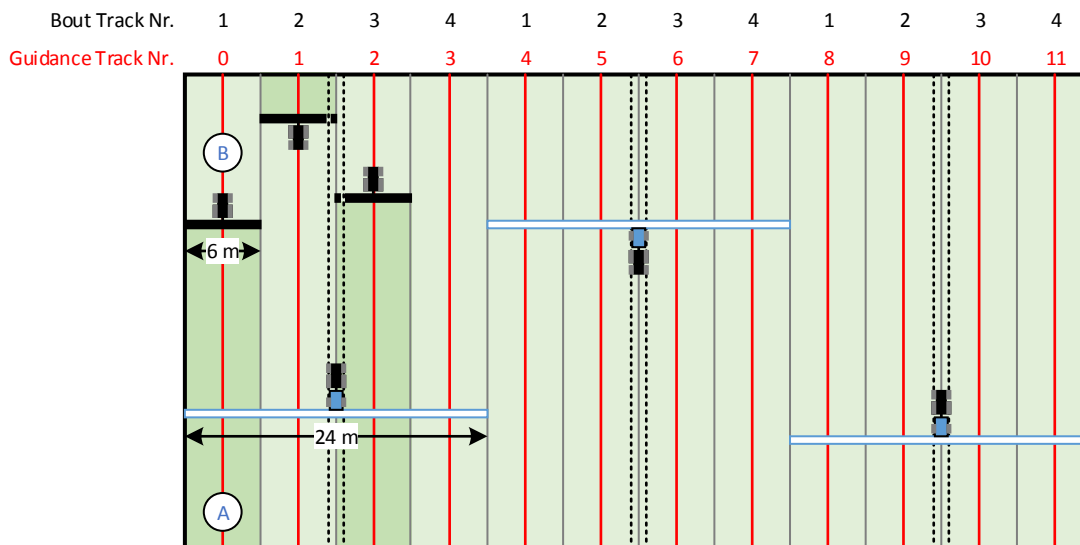

Figure 17: Asymmetric Tramlines, Seeder starts with 100% Working Width

The following picture shows a possible sequence diagram for the needed parameters.

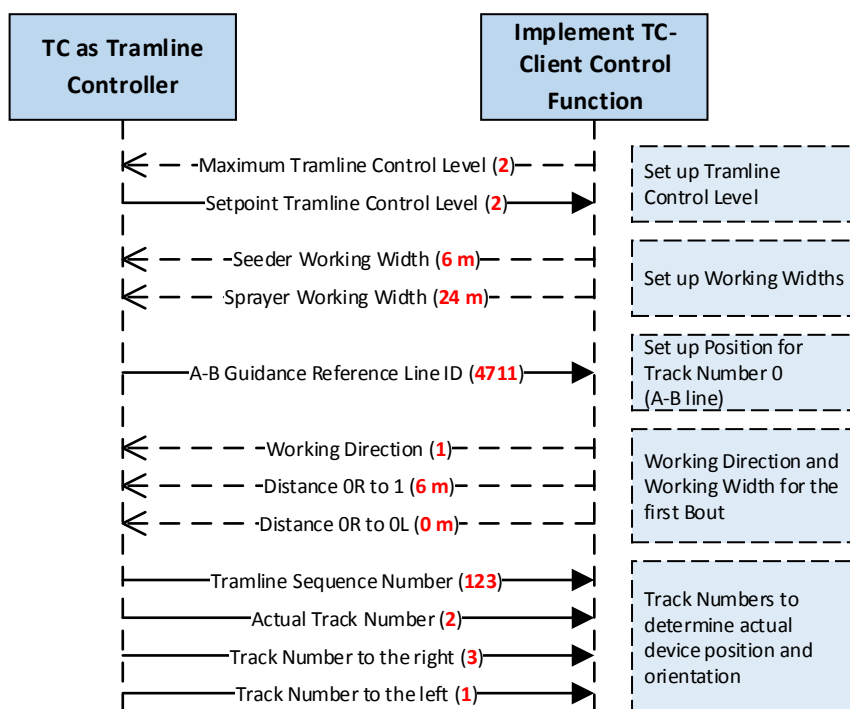

Figure 18: Sequence diagram - Asymmetric Tramlines, Seeder starts with 100% Working Width

### 3.2 Symmetric Tramlines, starting with 50% Working Width (left side working)

The Seeder with 6m Working Width starts working with a half Working Width (50%, 3m) on Guidance Track Number 0<sub>R</sub> in direction of A-B line. The Working Direction is 1, which means the Field Border is on the left hand side of the Implement and the Guidance Track Numbering is increasing from left to right in A-B direction. The Sprayer has a Working Width of 24m. This results





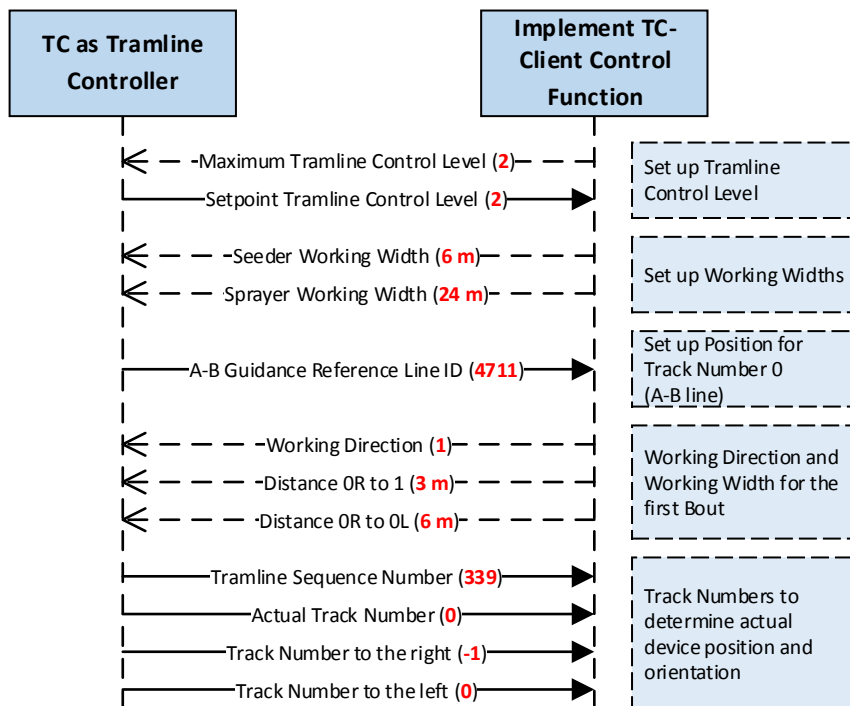
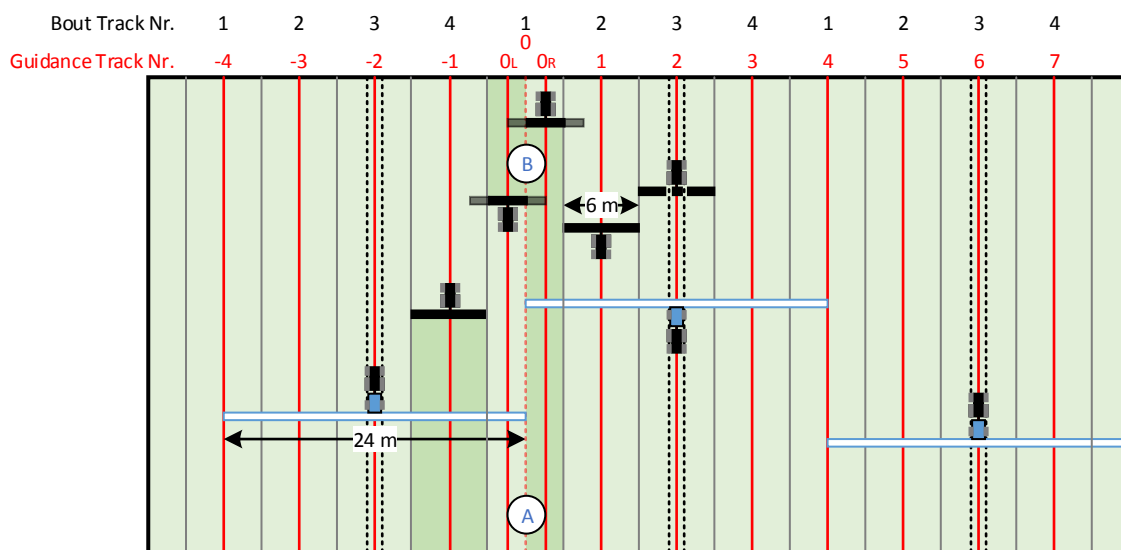

Figure 20: Sequence diagram - Symmetric Tramlines, Seeder starts with 50% Working Width (left or right side working)

### 3.3 Symmetric Tramlines, starting with 50% Working Width (middle working)

This is the same example as the described before. The difference is the property of the Implement to create a half Working Width.

In this case, the Seeder works both Tracks (0<sub>R</sub> and 0<sub>L</sub>) with half Working Width on the middle of the Implement. For that, the distance  $d_{0R/1}$  between Track Number 0<sub>R</sub> and 1 is 4.5m. On the other side of Track Number 0, the Guidance System has to create the line number 0<sub>L</sub>. The distance  $d_{0R/0L}$  between Track 0<sub>R</sub> and 0<sub>L</sub> is 3m.



**Figure 21: Symmetric Tramlines, Seeder starts with 50% Working Width (middle working)**

The following picture shows a possible sequence diagram for the needed parameters.

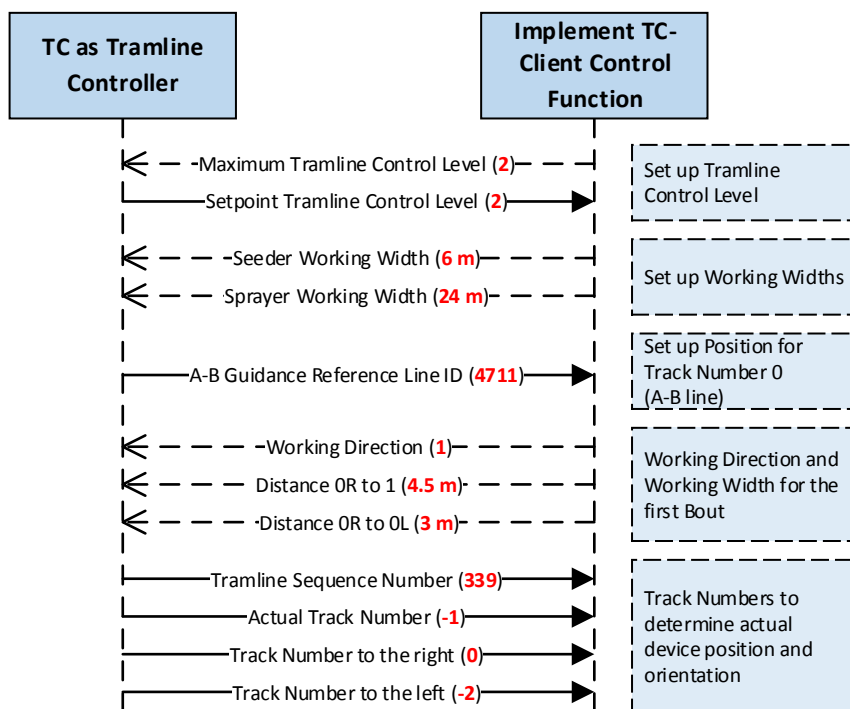
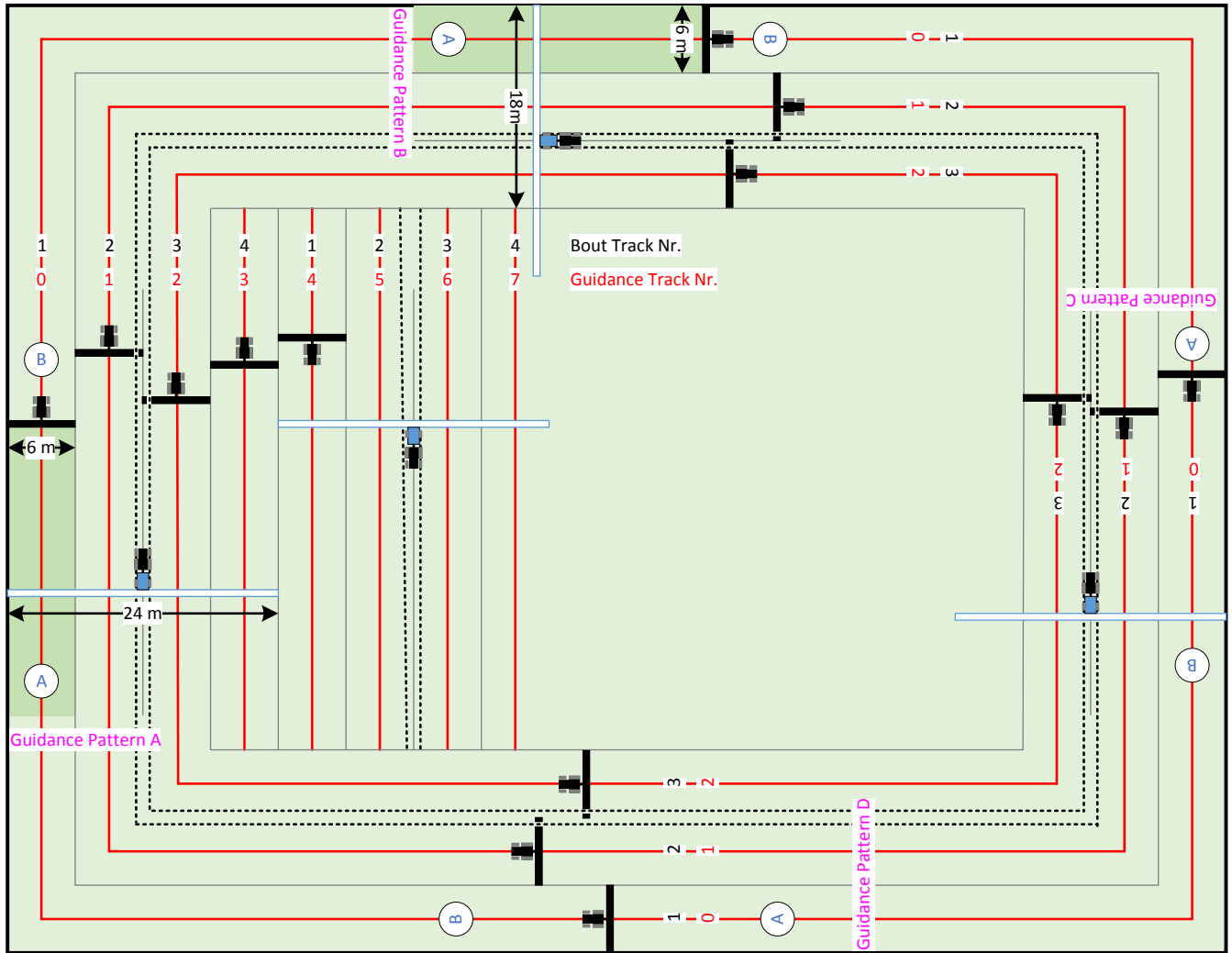

**Figure 22: Sequence diagram - Symmetric Tramlines, Seeder starts with 50% Working Width (middle working)**

### 3.4 Asymmetric Tramlines, first finish surrounding headland, then the main field

This example shows the situation where first 3 complete rounds in a surrounding headland are sown. For each round at first the area in Pattern A, then the Pattern B, then Pattern C and then Pattern D. This is done 3 times to fill up the surrounding headland area. Then the main field is finished, based on Pattern A. Every part of the field (Pattern) has its own A-B line.

For this example it is required to communicate the correct A-B Guidance Reference Line ID to the Implement.



**Figure 23: Asymmetric Tramlines, first finish surrounding headland, then the main field**

The following picture shows a possible sequence diagram for the needed parameters.

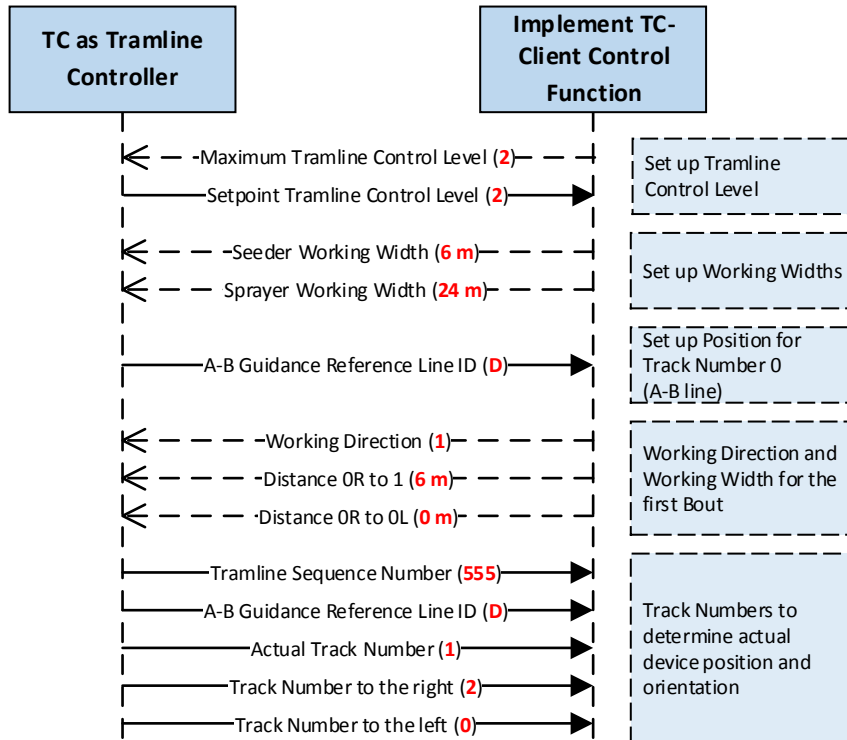

Figure 24: Sequence diagram - Asymmetric Tramlines, first finish surrounding headland, then the main field

## 4 Annex

### 4.1 Requirements for Tramline Control Level 3

This chapter describes a solution where the Tramline Controller is responsible for calculating the Tramline Tracks. The Tramline Controller will command the Implement to turn Tramline sections on or off.

A level 3 Tramline Controller will be able to command the following implements to apply tramlining:

- Implements without section control sections, but with a boom with one or more tramline sections. (Pneumatic seeders)
- Implements with a boom with section control sections and a second boom for tramline sections. (Pneumatic seeders)
- Implement with one boom where the section control sections can be used for tramlining. (Precision seeders)

A mandatory requirement for the implement is, is that it shall be able to switch each tramline section independently.

A Tramline controller needs the following information from an implement to apply proper tramlines in the field:

- Location of the tramline sections on the implement
- The working width of the tramline section

For Level 3 tramlining the following DDI's will be used:

- Tramline Control State
- Setpoint Tramline Condensed Section State
- Actual Tramline Condensed Section State

**Work flow:**

At start up the Implement uploads its DDOP to the Task Controller. If the Task Controller detects a DDI with the Tramline Level set to 3, it knows the implement supports Tramline commands.

The Tramline Controller provides a screen where the operator can enter the following information:

- Sprayer width
- Tramline Wheel Track Distance
- etc.

When the operator has entered this information, the Tramline Controller verifies if this information match with the information provided in the DDOP of the Implement. It is the Tramline Controller's responsibility to inform the operator in case of any incompatibility.

**Example:**

The Tramline Wheel Distance is set to 1,5m but the Tramline valves on the implement are configured for a 2 m Tramline Wheel Distance.

When the farmer has entered a valid configuration, the Tramline Controller will be allowed to send Tramline Condensed Section States to the implement.

The following pictures show different examples of DDOPs for Tramline Control.

Case 1: TC-TRC DDOP Example. DDOP without sections control sections but with Tramline Sections.

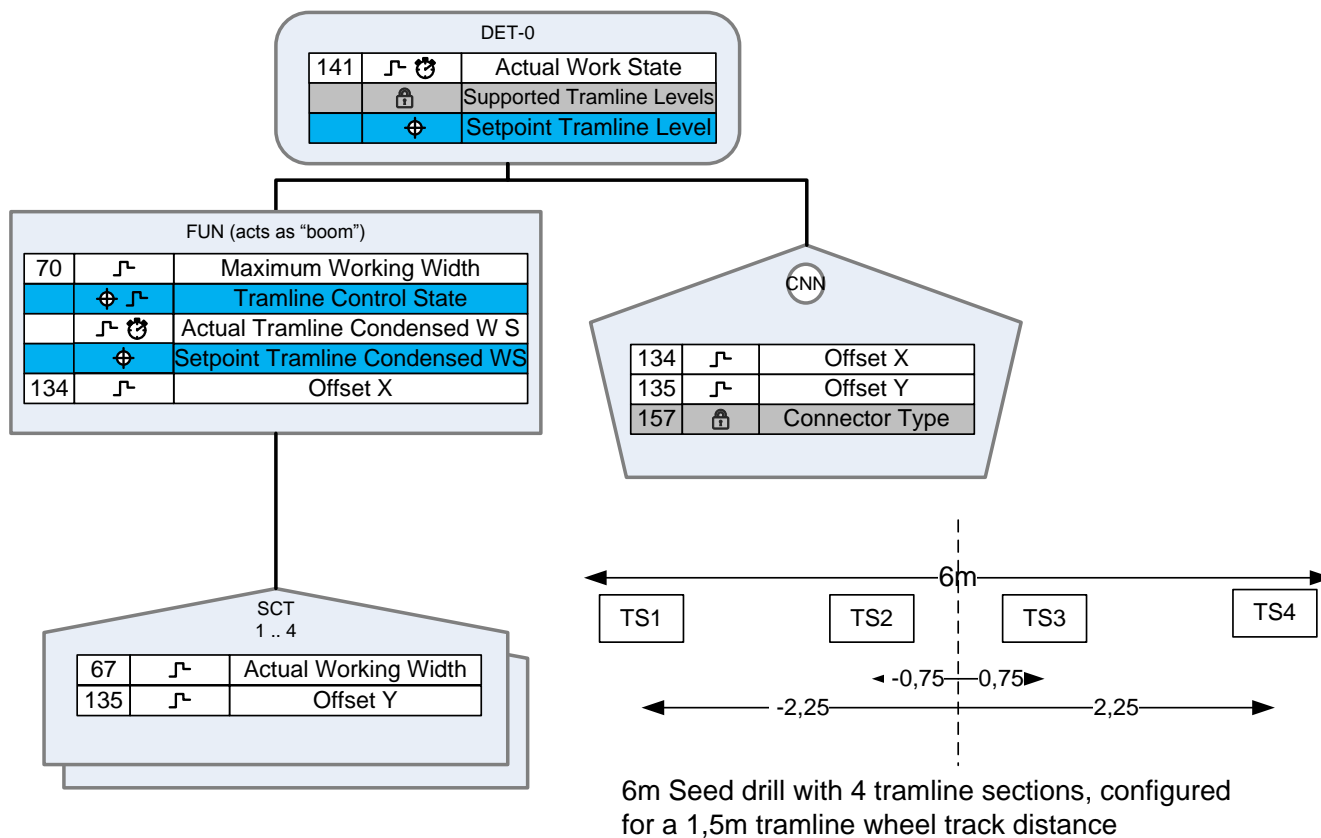

**Example of a 6m drill, with 4 tramline sections.**

The tramline wheel track distance is fixed to 1,5 m.

Sprayer width of 18m:

Rhythm 1 to 3.

Bout 2: Tramline Sections TS 2 and TS 3 are activated.

Sprayer width of 24m:

Working left to right:

Rhythm 1 to 4.

Bout 2: Tramline Section TS 1 is activated.

Bout 3: Tramline Section TS 1 is activated.

Sprayer width of 24m:

Working right to left:

Rhythm 1 to 4

Bout 2: Tramline Section TS 4 is activated.

Bout 3: Tramline Section TS 4 is activated.

Case 2: TC-TRC DDOP Example: Section Control Boom with 2 sections and a second boom with 4 Tramline Sections

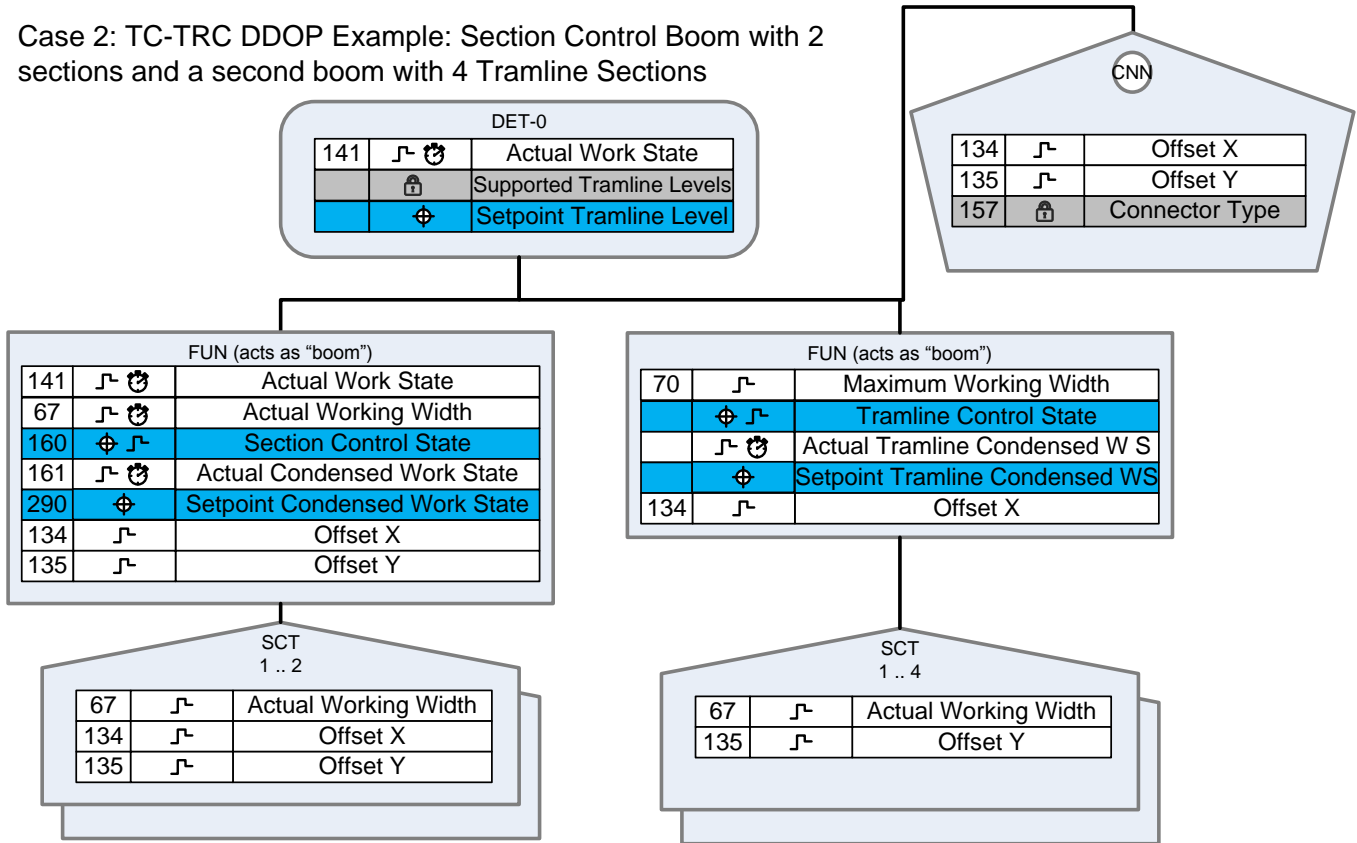

**Example of a 6m drill, with 4 tramline sections and 2 sections.**

The tramline wheel track distance is fixed to 1,5 m.

Sprayer width of 18m:

Rhythm 1 to 3.  
Bout 2 : Tramline Sections TS 2 and TS 3 are activated.

Sprayer width of 24m:

Working left to right:  
Rhythm 1 to 4  
Bout 2: Tramline Section TS 1 is activated.  
Bout 3: Tramline Section TS 1 is activated.

Sprayer width of 24m

Working right to left:  
Rhythm 1 to 4.  
Bout 2: Tramline Section TS 4 is activated.  
Bout 3: Tramline Section TS 4 is activated.

Sprayer width of 24m Symmetric:

First bout with one section activated.  
All other bouts both sections are activated.  
Bout 3: Tramline Section TS2 and TS3 are activated.

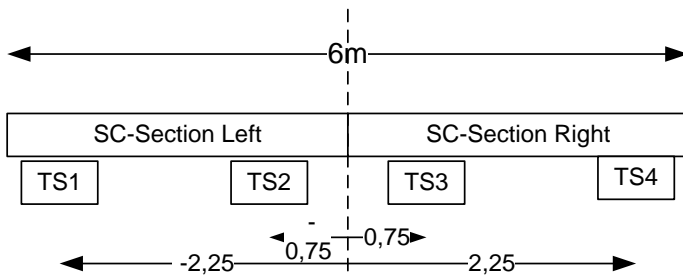



Case 3: TC-TRC DDOP Example. Section Control Boom with Tramline Sections

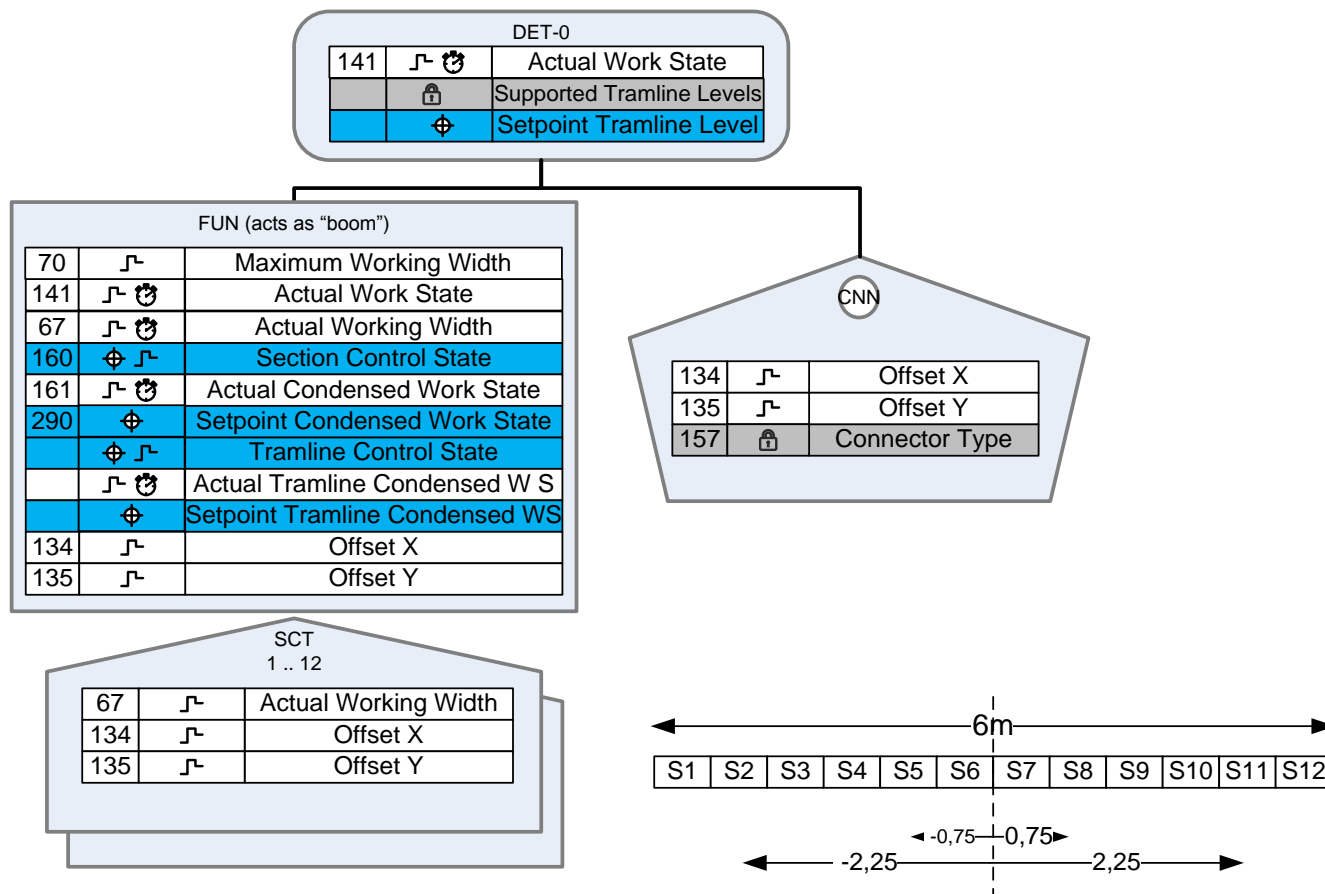

**Example of a 6m drill, with 12 sections, which can also be used for tramlining.**

The tramline wheel track distance is set to 1,5 m.

Sprayer width of 18m:

Rhythm 1 to 3.

Bout 2: "Tramline Sections" S 5 and S 8 are activated.

Sprayer width of 24m:

Working left to right:

Rhythm 1 to 4

Bout 2: "Tramline Sections" S 2 is activated.

Bout 3: "Tramline Sections" S 2 is activated.

Sprayer width of 24m:

Working right to left:

Rhythm 1 to 4.

Bout 2: "tramline section" S 11 is activated.

Bout 3: "tramline section" S 11 is activated.

Sprayer width of 24m Symmetric.

First bout with 6 section activated.

All other bouts all sections are activated.

Bout 3: "Tramline sections" S5 and S8 are activated.

Note:

With this configuration many tramline rhythms are possible, because each section can be used as a tramline section.